

COMPONENTS FOR SURFACE ANALYSIS

## Thermal Gas Cracker **TGC-H**

- Atomic hydrogen source
- Very high cracking efficiency
- Negligible ion emission design
- Easy filament replacement
- Optical viewport option

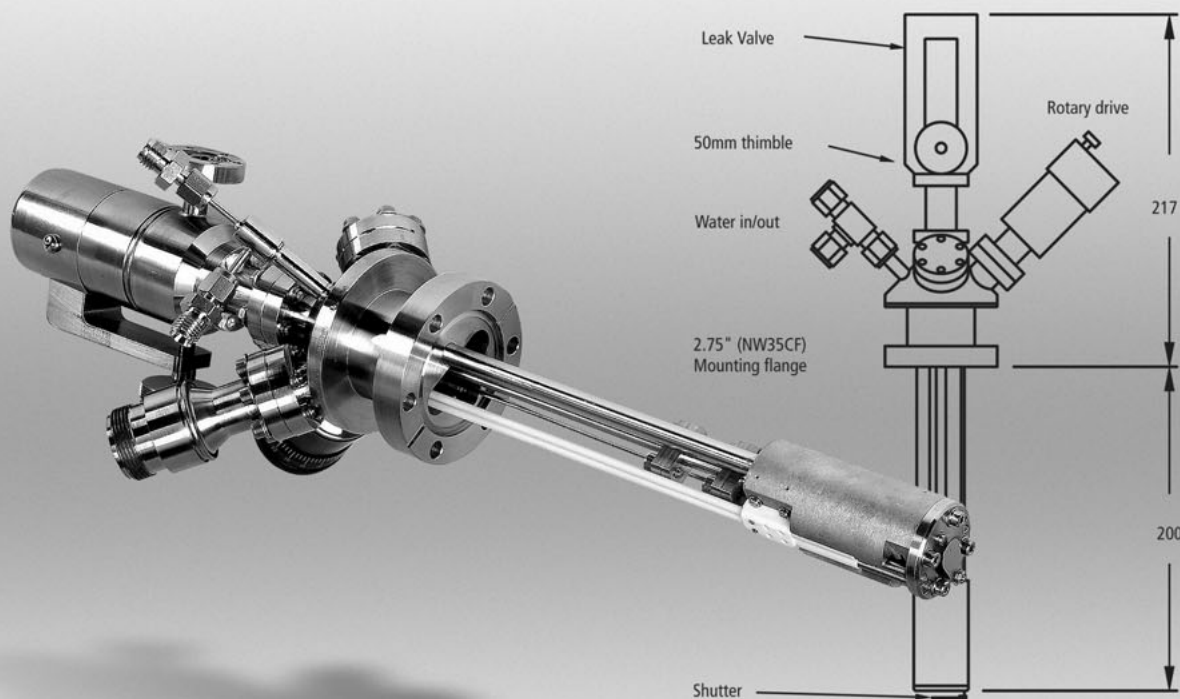

# The Thermal Gas Cracker TGC-H

The SPECS TGC-H is a fully UHV compatible thermal gas cracker source using electron bombardment heating of a tungsten capillary to thermally dissociate the gas passing through it. The cracking efficiency is determined by the equilibrium thermodynamics of the dissociation of hydrogen molecules into atoms. For capillary temperatures of 1400°C or more and pressures

below 10<sup>-8</sup> mbar this is nearly 100 %. The small size and thermal mass of the capillary means that very little power is required with negligible heat load into the system. The filament itself is easy to exchange. Moreover, no differential pumping is needed for operation in UHV and due to the electrically grounded capillary zero ion emission is achieved.

## Main Features:

- Mounting flange: 2.75" (NW35CF)
- In vacuum length: 200 mm
- In vacuum diameter: 34 mm max.
- Bakeout temperature: 200° C
- Beam divergence: ~15° half angle
- Gas flow: 10<sup>-5</sup> - 1 sccm
- Operating pressure: < 10<sup>-10</sup> - 10<sup>-5</sup> mbar
- Hydrogen flux: 5 x 10<sup>13</sup> atoms/cm<sup>2</sup> at 10 cm distance
- Cracking efficiency: Approaching 100 %
- E-beam power: 0 - 60 W

## Options:

- Integrated shutter
- Shutter motorisation for integrated shutter option
- Optical viewport provides a direct view of the cracking zone
- Thermocouple (Type C) to measure the tungsten capillary temperature (with feedthrough)
- PID controller to be used with thermocouple option

## New Design Features:

- The evaporation zone is completely enclosed by a water-cooled copper shroud. The cooling water sees only stainless steel and welded joints for long term corrosion resistance, with the stainless steel cooling pipes permanently bonded through the copper for complete and reliable thermal contact.
- An optical viewport option provides direct view of the cracking zone inside the tip of the tungsten capillary for visual confirmation, optical pyrometry and spectrometry.
- The filament assembly can be easily replaced without major disassembly of the evaporator head. Spare filament assemblies can be purchased or prepared in advance and can be easily replaced without disassembling the evaporator head.

## Applications:

- Removal of residual oxygen and carbon by reduction to volatile hydrides
- Low temperature cleaning
- Surfactant - promoting 2-D growth
- Post growth surface treatment/improvement
- Chemical passivation and surface reconstruction
- Annealing of amorphous silicon

SPECS GmbH - Surface Analysis  
and Computer Technology  
Voltastr. 5  
13355 Berlin  
Germany



Phone.: +49 (0)30 467824 - 0  
Fax: +49 (0)30 4642083  
E-mail: support@specs.de  
http://www.specs.de

Your Representative: