

COMPONENTS FOR SURFACE ANALYSIS

Electron Beam Evaporator EBE-1

- Suitable for various materials
- Unique high reliability design
- Extremely high power densities
- Temperatures in excess of 3000 K
- Evaporation from rods and crucibles

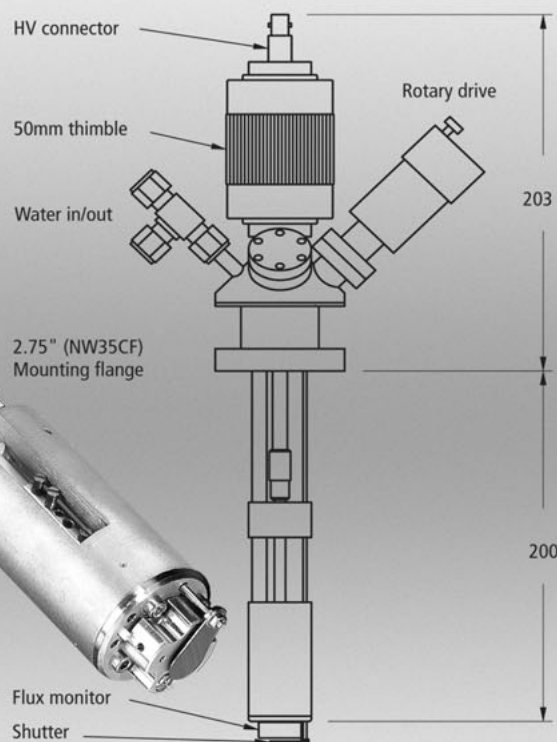
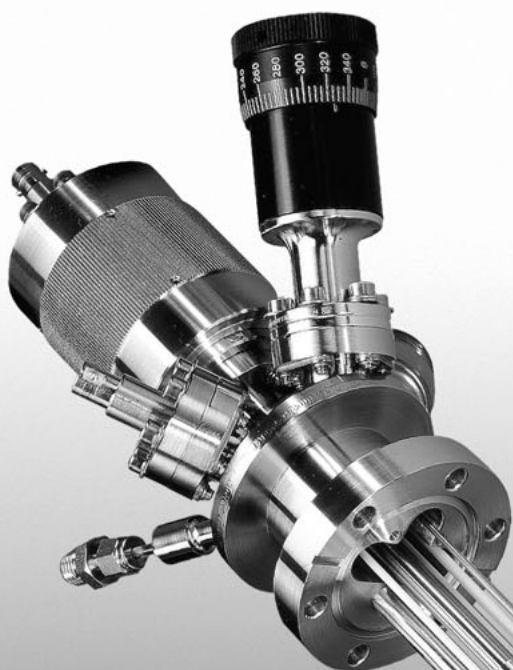

The Electron Beam Evaporator EBE-1

The SPECS EBE-1 is a combined mini e-beam evaporator and e-beam heated effusion cell capable of evaporating small quantities of almost any material. The material either in rod form, or in a crucible, is heated by electron bombardment

Applications:

Pt:	Thin films, surface science. From rod/crucible
Cr:	Metalising, contacting. From rod - sublimes
Al ₂ O ₃ :	Optical films, oxide films. From crucible
C:	Doping, SEM sample preparation. From rod
Au, Ag:	Metalising, contacting. From crucible
Cu:	Surface science. From crucible
Nb:	From rod

Main Features:

- **Mounting flange: 2.75" (NW35CF)**
- **In vacuum length: 200 mm**
- **Bakeout temperature: 200° C**
- **Max. rod diameter: 6 mm**
- **Rod feed: Up to 50 mm**
- **Crucible size: 0.25 cc**
- **Operating pressure: < 10⁻¹⁰ - 10⁻⁵ mbar**
- **Power supply with controller: 400 W**
- **Internal water-cooling**

Options:

- **Non standard lengths 150 - 500 mm**
- **Integrated shutter**
- **Electric motorization of manual shutter**
- **0.25 cc crucibles from C, Mo, Ta and W**
- **Clusterflange for up to three EBE-1 units**
- **Flux measurement electrode and feedthrough**
- **Flux monitor and flux controller**
- **Thermocouple (Type C) and feedthrough**

from the surrounding filament. The capacity for electrons to be directed to deliver up their energy in a confined area, leads to extremely high power densities and local heating and allows temperatures in excess of 3000 K.

New Design Features:

- The unique design, incorporating both the high voltage and optional thermocouple feedthroughs on an exclusively designed 2" linear motion thimble means that there are no flexing leads in vacuum which could lead to fatigue and shorting problems. The thermocouple can be used while operating from either rod or crucible and allows the instrument to be used as a true e-beam heated effusion cell.
- The evaporation zone is completely enclosed by a water-cooled copper shroud. In this design the cooling water sees only stainless steel for long term corrosion resistance.
- The filament can be easily replaced without disassembling the evaporator head by simply using standard tungsten wire.
- The filament encircles the rod or crucible providing more even heat distribution.
- A long filament provides more surface area for electron emission with a consequent improvement in filament lifetime.
- Fine control of the electron emission current for improved operation at very low rates and 50 mm rod feed are provided as standard.
- The power supply design is able to evaporate the thickest rods (6 mm) and is robust enough to survive misuse without dire consequences seen in more complex failure prone electronics.

SPECS GmbH - Surface Analysis
and Computer Technology
Voltastr. 5
13355 Berlin
Germany



Phone.: +49 (0)30 467824 - 0
Fax: +49 (0)30 4642083
E-mail: support@specs.de
http://www.specs.de

Your Representative: